

FEATURES & SPECIFICATIONS

INTENDED USE — Suitable for applications requiring attractive edge-lit exit signage, universal installation and low energy consumption.

CONSTRUCTION — Extruded brushed aluminum finish.

Clear acrylic panels- letters measure 6" high with 3/4" stroke, with 100 ft viewing distance rating, based upon UL 924 standard.

For single-face clear panels, EXIT is seen as a reversed image from the back.

OPTICS — LEDs mounted on printed circuit board. The typical life of the exit LED lamp is 10 years.

The LED operating frequency is 120Hz.

ELECTRICAL — Dual voltage input capacity (120/277V).

Battery: (EL Option) – Sealed, maintenance free nickel-cadmium battery delivers 90 minutes capacity to emergency lamps. Test switch provides manual activation of 30-second diagnostic testing for on-demand visual inspection.

Self-diagnostic testing (EL Option Only) for 30 seconds every 30 days and 90 minutes annually. Diagnostic evaluation of LED light source, AC to DC transfer, charging and battery condition.

INSTALLATION — EDG – Universal surface (top, end or back) mounting. Canopy provided.

EDGR – Recessed mounting. Bar hanger and brackets provided for both new or restricted ceiling access installation applications. Back wall mount (WM) option.

Universal directional indicators. Field selected and attached.

LISTINGS — UL damp location listed 32°-122°F (0°-50°C) standard. Meets UL924, NFPA 101 (current Life Safety Code), NEC and OSHA illumination standards.

WARRANTY — 5-year limited warranty. Complete warranty terms located at:

www.acuitybrands.com/support/customer-support/terms-and-conditions

NOTE: Actual performance may differ as a result of end-user environment and application.

All values are design or typical values, measured under laboratory conditions at 25°C.

Specifications subject to change without notice.

Catalog Number
Notes
Type



EDG (surface mount)



EDGR (recessed mount)

LED Edge-Lit Exits

EDG EDGR

LED Lamps



Specifications

EDG (End Mount)	EDG (Top Mount)
Length: 13-5/8 (34.6)	Length: 13 (33.0)
Depth: 5-1/2(14.0)	Depth: 4-5/16 (11.0)
Height: 11-1/8 (28.3)	Height: 11-3/4 (29.8)
Shipping Weight : 4 lbs (1.8 kgs)	Shipping Weight : 4 lbs (1.8 kgs)
EDG (Back Mount)	EDGR
Length: 13 (33.0)	Length: 13 (33.0)
Depth: 3 (7.6)	Depth: 1-3/4 (4.4)
Height: 11-1/8 (28.3)	Height: 8 (20.3)
Shipping Weight : 4 lbs (1.8 kgs)	Shipping Weight : 6.8 lbs (3.1 kgs)
	Shipping Weight (WM option) : 8.1 lbs (3.7 kgs)

All dimensions are inches (centimeters) unless otherwise noted.

ORDERING INFORMATION

For shortest lead times, configure products using **bolded options**.

Example: EDG 1 R EL

Family	Housing color	Number of faces	Letter color	Operations	Options
EDG Surface mount LED edge-lit exit	(blank) Brushed aluminum	1 Single face	R Red on clear (single face only) ¹	(blank) AC only	(blank) None
EDGR Recessed LED edge-lit exit	W White	2 Double face	G Green on clear (single face only) ¹	EL Nickel-cadmium battery	WM Recessed wall mount ⁶
			RMR Red on mirror ²	X2 Lamp wired on two separate AC circuits (specify 120V or 277V) ⁴	
			GMR Green on mirror ²	SD Self-diagnostics ⁵	
			RW Red on white ³		
			GW Green on white ³		

Notes

- For single-face clear panels, EXIT is seen as a reversed image from the back.
- Available with single and double face.
- White panel standard for double and single face.
- Not available with EL and SD options. Both circuits can be energized at the same time.
- Available with EL option only.
- Available on EDGR single face only
- See spec sheet [ELA-StemKits](#). Only available for EDG.
- Back mount only.

Accessories: Order as separate item.	
ELA US12	12" stem kit with brushed aluminum canopy ⁷
ELA W US12	12" stem kit with white canopy ⁷
ELA WG1	Wireguard ⁸

EDG-EDGR LED, Surface and Recessed Mount Edge-Lit Exits

SPECIFICATIONS

ELECTRICAL						
Primary Circuit						
Type	Typical LED life ¹	Supply voltage	EDG		EDGR	
			Input Watts	Max amps.	Input Watts	Max amps.
Red LED AC only	10 years	120	2.5	0.020	3.8	0.030
		277	2.8	0.010	4.5	0.014
Green LED AC only	10 years	120	2.2	0.020	3.8	0.030
		277	2.2	0.010	4.5	0.020
Red LED emergency	10 years	120	3.0	0.030	3.8	0.031
		277	3.1	0.010	4.5	0.015
Green LED emergency	10 years	120	2.6	0.020	3.8	0.031
		277	2.8	0.010	4.5	0.020

BATTERY (EL option)			
Sealed Nickel-Cadmium			
Shelf life ²	Typical life ²	Maintenance ³	Optimum temperature ⁴
3 years	7-9 years	none	32-122°F (0-50°C)

Notes

- Based on continuous operation. The typical life of the exit LED lamp is 10 years.
- At 77°F (25°C).
- All life safety equipment, including emergency lighting for path of egress must be maintained, serviced, and tested in accordance with all National Fire Protection Association (NFPA) and local codes. Failure to perform the required maintenance, service, or testing could jeopardize the safety of occupants and will void all warranties.
- Optimum ambient temperature range where unit will provide capacity for 90 minutes. Higher and lower temperatures affect life and capacity.

KEY FEATURES

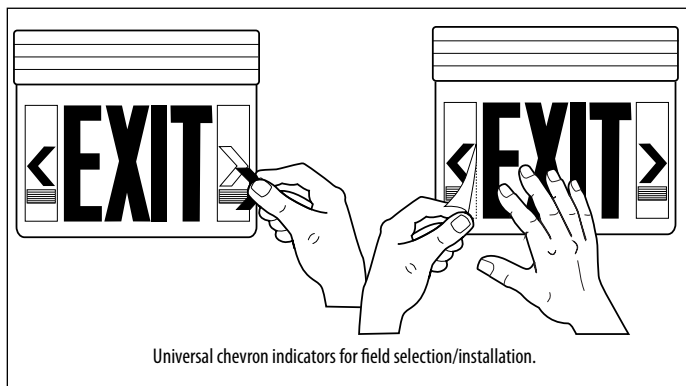

MOUNTING

EDG

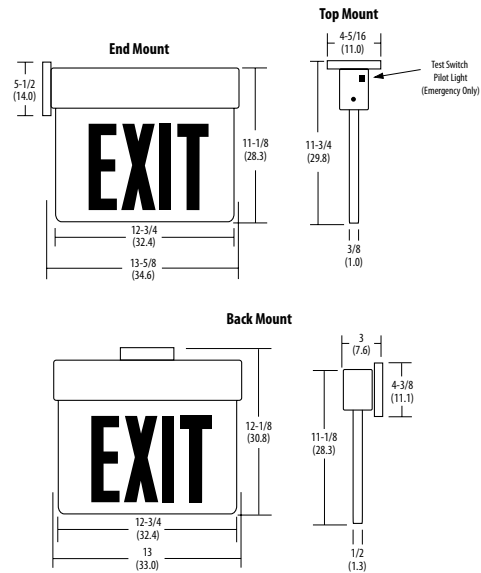

EDGR

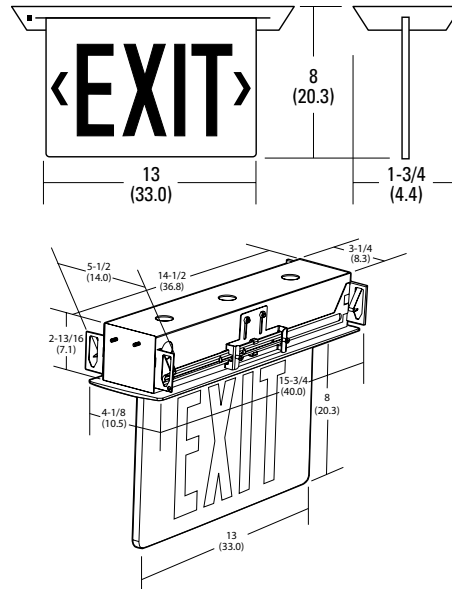

EDGR WM option

